

LOWRANCE

Outboard pilot, Cable steer pack Installation Guide

ENGLISH



www.lowrance.com

Technical specifications

1

NAC-1	
Operating temperature	-25°C to +55°C (13°F to 131°F)
Protection	Splashproof, IPx5
Weight	0.6 kg (1.3 lbs)
Power supply	9-16 V DC
Load	140 mA + drive unit load
Performance	Drive: 8 A cont., 16 A for 1 s
Point-1	
Operating temperature	-25°C to +60°C (13°F to 140°F)
Protection	Watertight, IPx7
Weight	0.14 kg (0.31 lbs)
Power supply	9-16 V DC
Load	<100 mA @ 12 V DC
Performance	Heading: +/- 3°, Horiz. accuracy: 3 m (9.8 ft)
Standby/Auto button	
Operating temperature	-25°C to +55°C (13°F to 131°F)
Protection	Splashproof, IPx5
Weight	0.04 kg (0.09 lbs) (including cable)
Helm-1	
Operating temperature	-15°C to +75°C (5°F to 167°F)
Protection	Splashproof, IPx5
Weight	4.6 kg (10.14 lbs)
Load	Motor: 1.3 A (no load), max 5 A, Clutch: 0.8 A
Performance	HO-HO 15 s (no load), Max thrust 1.300 N (290 lbs)
RC42N	
Operating temperature	0°C to +55°C (32°F to 131°F)
Protection	IP56
Weight	0.4 kg (0.9 lbs)
Power supply and interface	8-16 V via NMEA 2000
Power consumption	1.4 W
Accuracy	± 3 degrees after calibration
Compass safe distance	0.5 m (1.7')

PLANNING: Tools needed

2

- Use to mount Helm-1, NAC-1 and heading sensor.
- Drill holes for screws.
- Wrenches that fit the hoses.
- Tools to connect power cables at battery.

PLANNING: Cable lengths

3

- Refer to Wiring diagram (point 15) to find the various cable lengths.

PLANNING: Dimensions

4

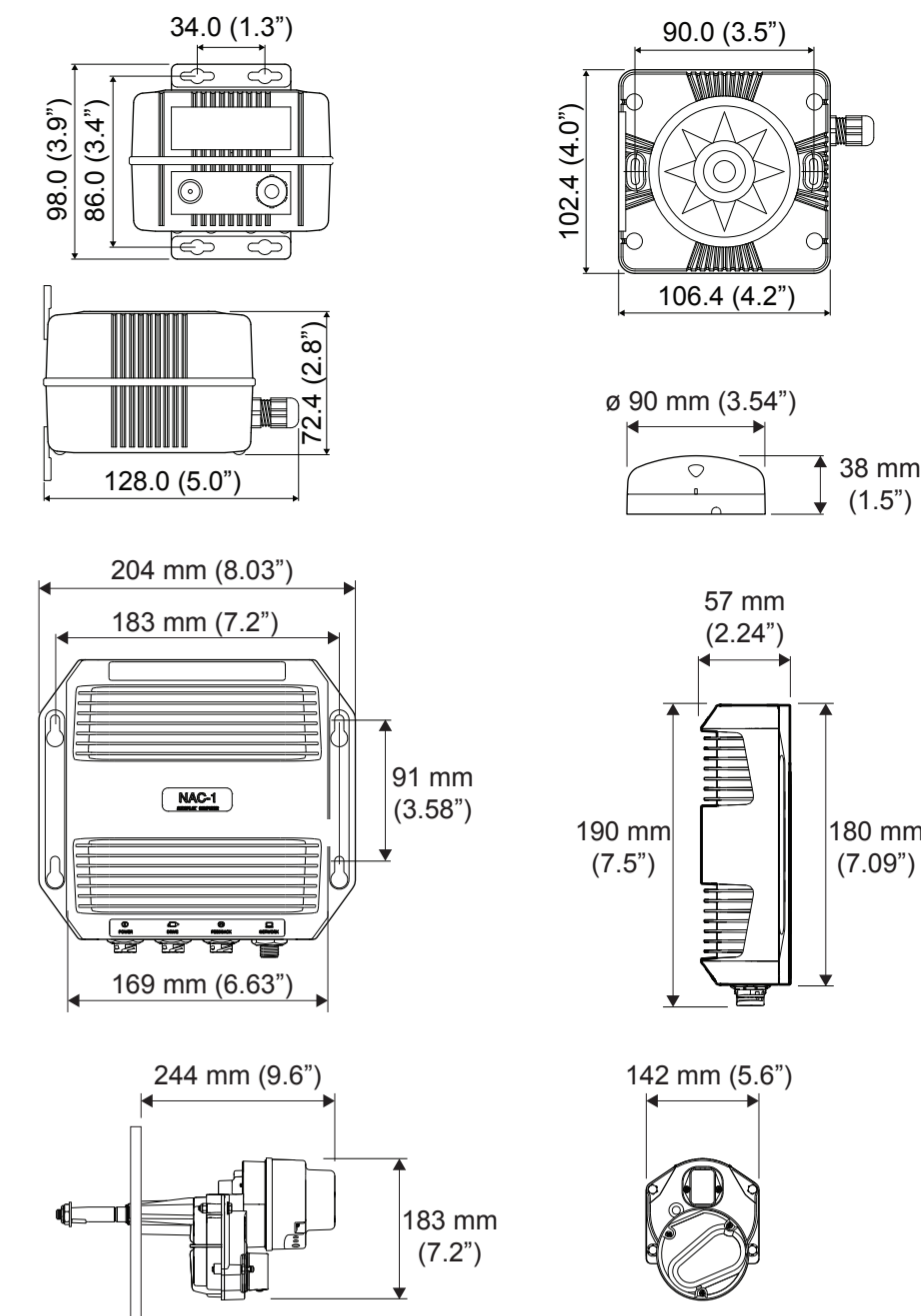

PLANNING: Point-1, Mounting location

5

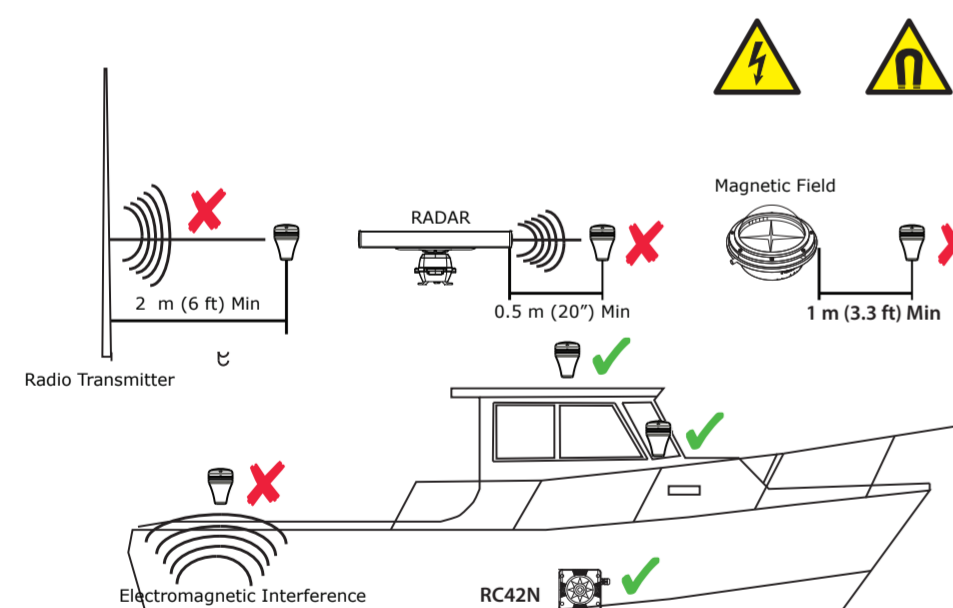

Point-1

The antenna contains a magnetic heading sensor and should not be mounted within 1 meter (3.3 ft) of any potential magnetic source.

RC42N

Select a location that provides a solid mounting place free from vibration, min. 1 meter (3.3 ft) away from any potential magnetic source, and as close to the vessel's centre of roll and pitch as possible, i.e. close to the water line.

Potential sources for magnetic/electromagnetic interference include:

- Electrical Motors/Magnets/Moving Metal items
- Outboard Engines
- High current electrical sources such as main power cables, batteries, distribution panels etc.

Compatibility information

6

The drive unit either replaces or is used in conjunction with common brands of mechanical rotary and rack and pinion steering helm units. The drive is based on the Morse 290 rotary helm unit and accepts Morse 304411 and Teleflex SSC52 rotary cables without modification. If the boat is fitted with any of the following systems:

**Teleflex Safe T or Teleflex Big T Uflex T71
Uflex T73NR or Uflex T81**

A cable adapter must be fitted to the cable before installing the drive.

If the boat has a rack and pinion type steering system (or other brands of rotary system), the drive can be used, but the steering cable must also be replaced with a Morse 304411 or Teleflex SSC52.

The drive is designed to produce a maximum cable push/pull of 136 kg, which makes it suitable for the vast majority of cable steered boats. However, some boats fitted with push-pull cable steering systems have very stiff steering or steering which is heavily loaded in one direction due to hull design and engine considerations. Generally speaking, the drive will steer boats that do not require more than a 7 kg force on the rim of a 35 cm diameter steering wheel to hold a course, this equals 1.2 kgm of torque. If the steering wheel input torque exceeds this figure it is recommended that a hydraulic linear actuator drive system is used.

Remove steering cables from existing manual helm

7

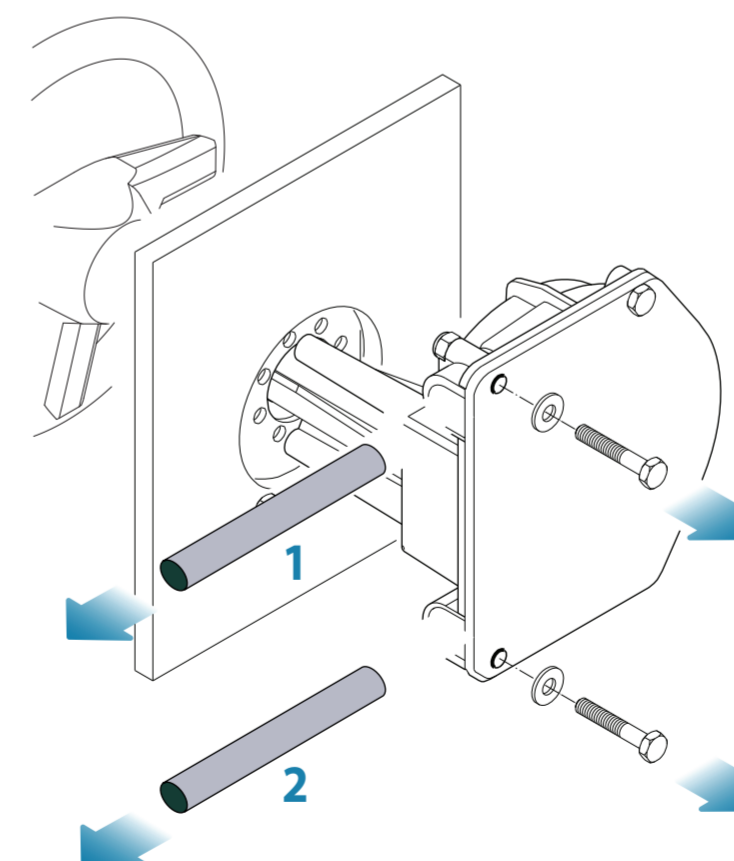

Remove existing manual helm from dashboard

8

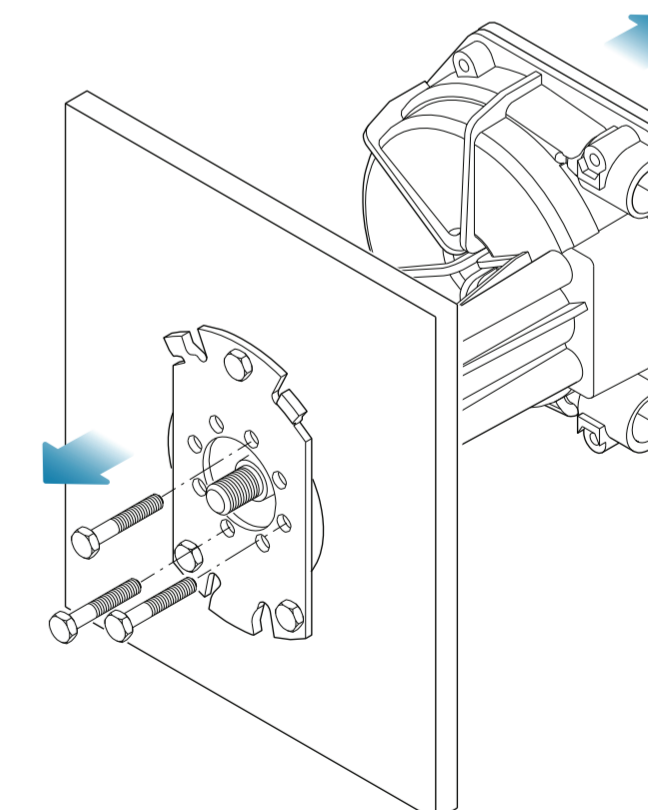

Install Helm-1 to dashboard

9

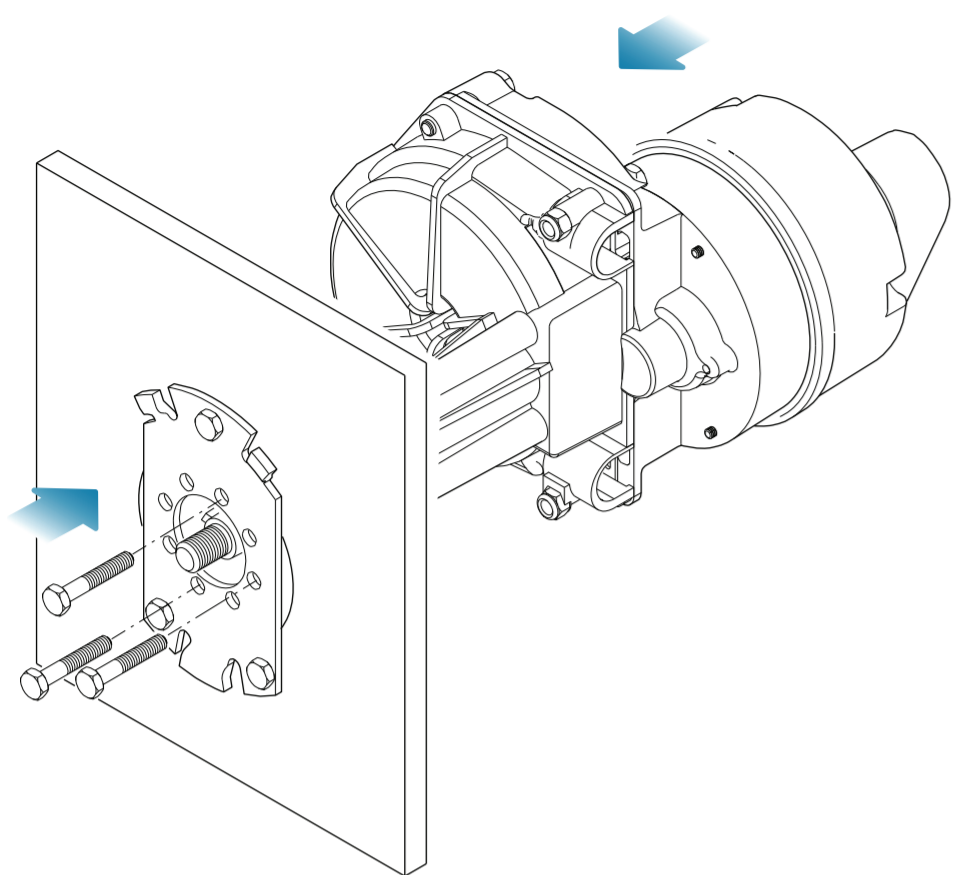

Install steering cables to Helm-1

10

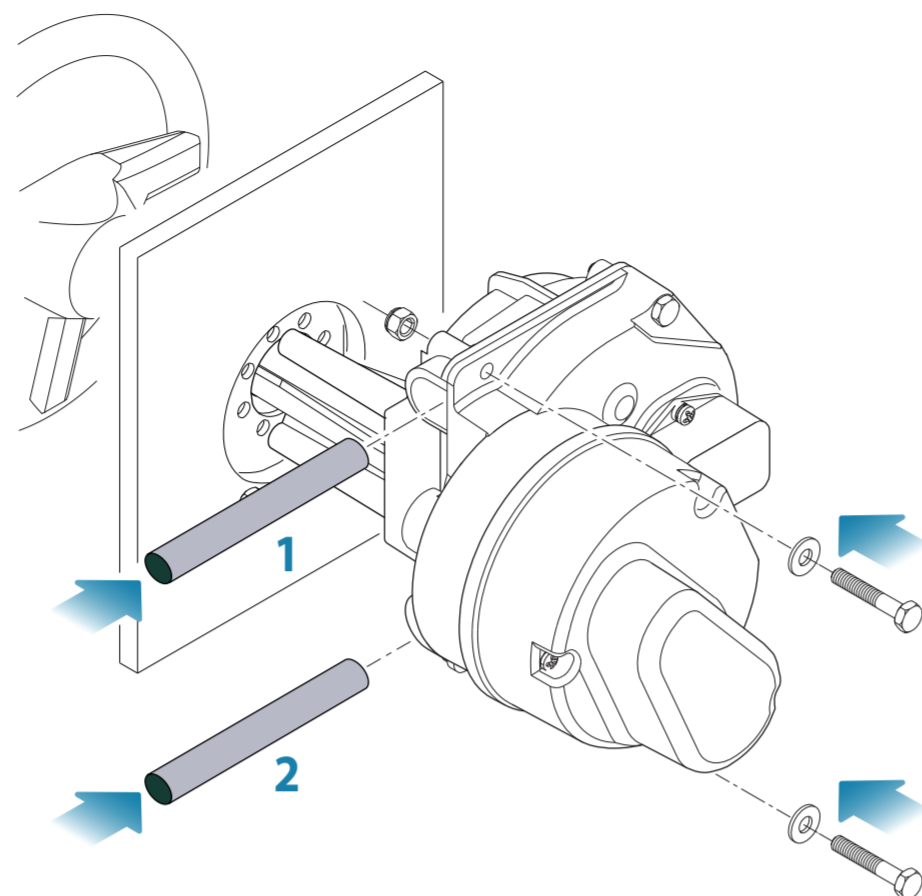

Helm-1, Rudder feedback calibration

11

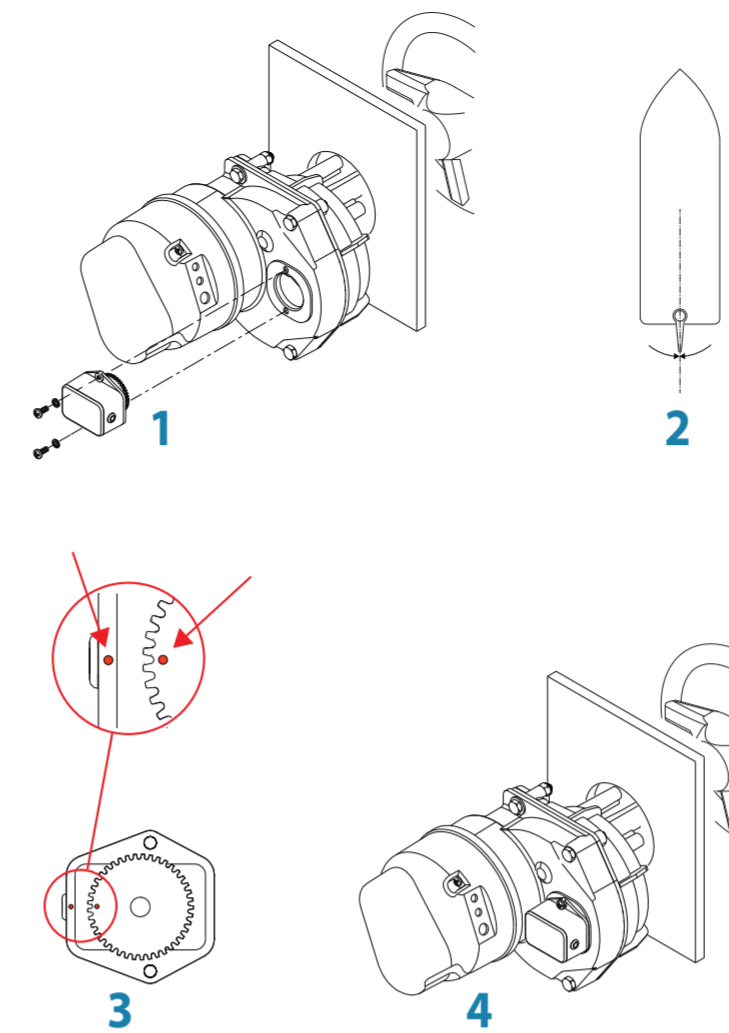

- 1 Remove the rudder feedback sensor from the drive unit
- 2 Centre the steering
- 3 Align the 2 red dots
- 4 Fit the rudder position sensor to the drive unit.

MOUNTING: NAC-1

12

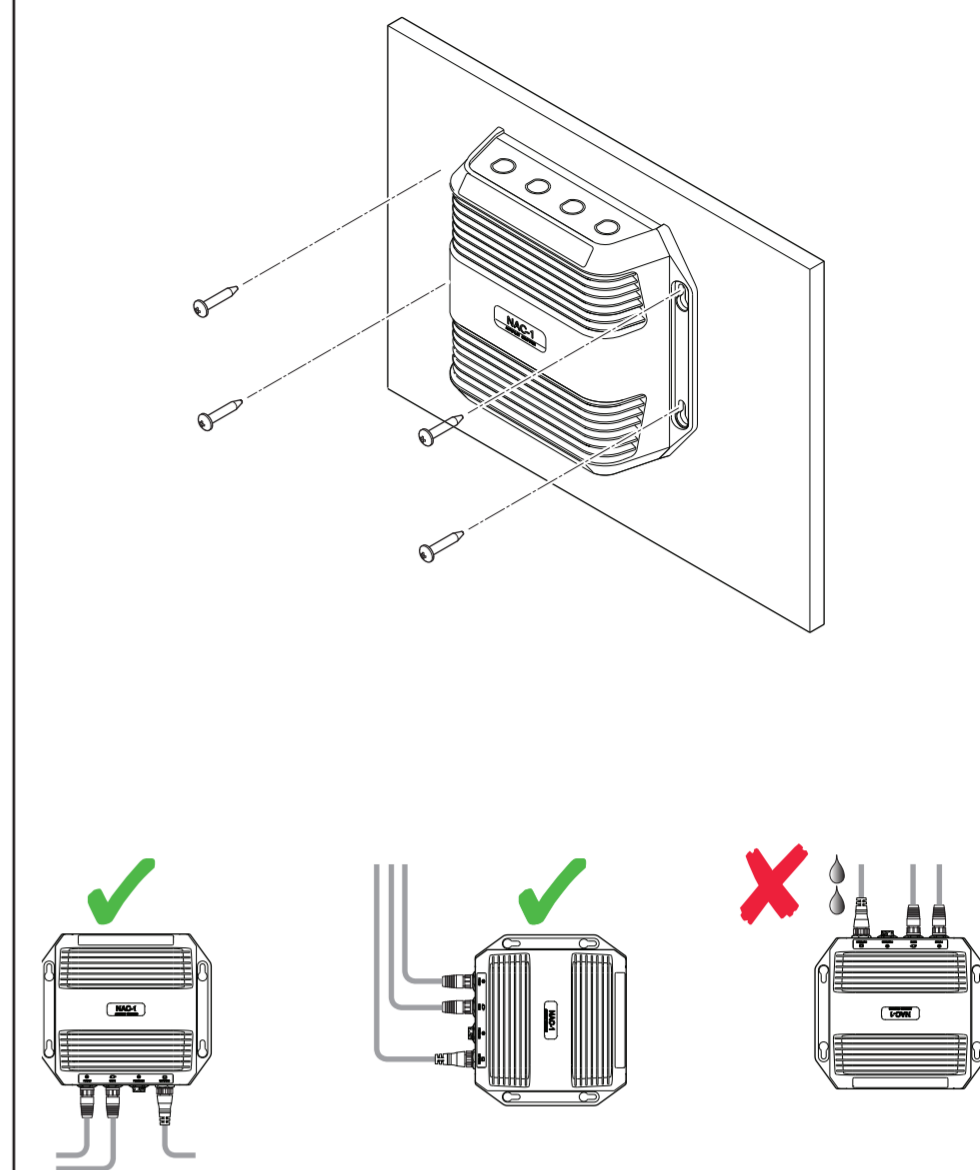

MOUNTING: RC42N

13

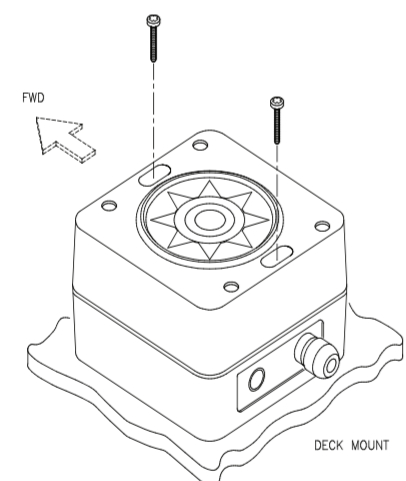

DECK MOUNT

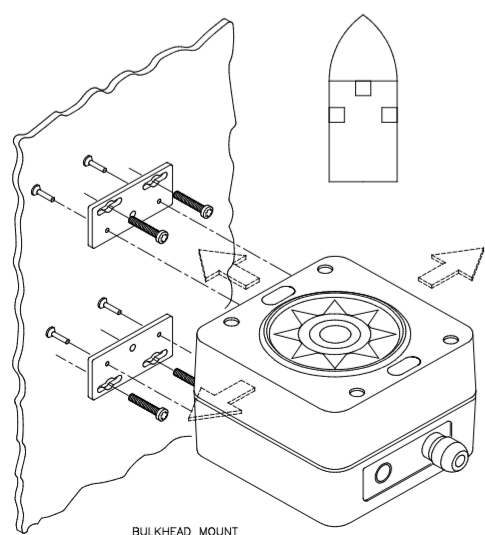

BULKHEAD MOUNT

MOUNTING: Point-1

14

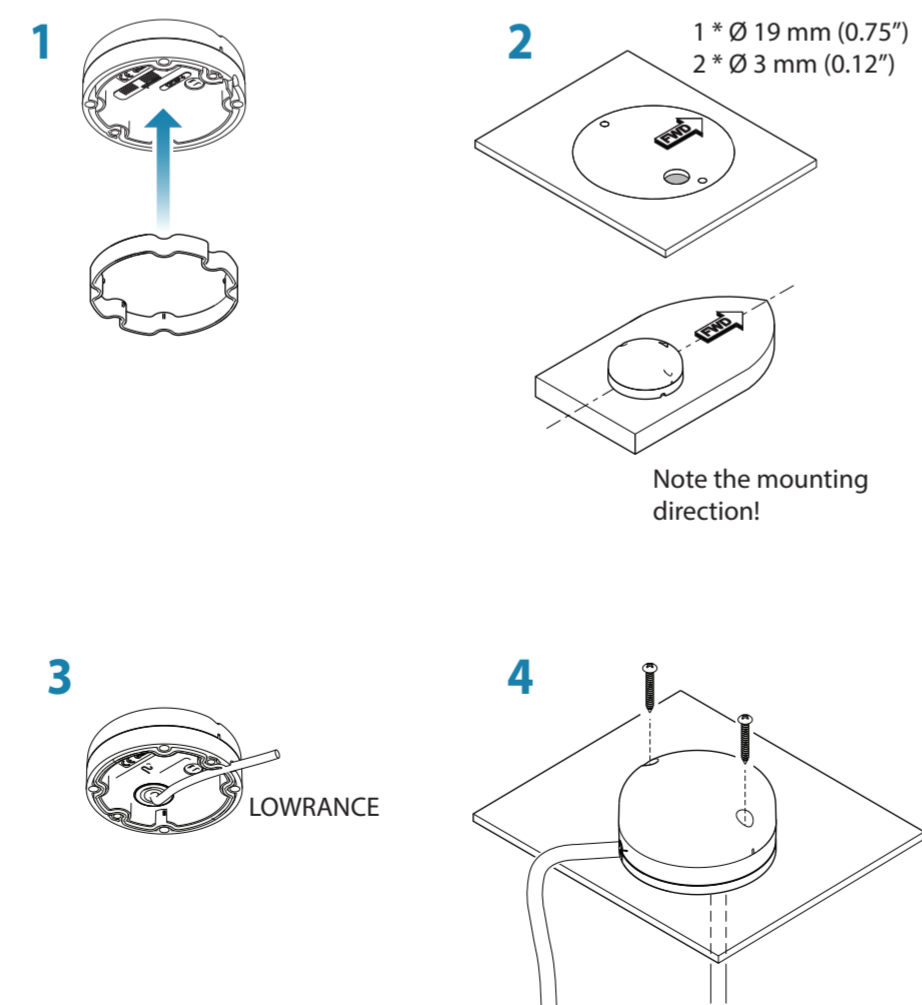

WIRING: Wiring diagram

15

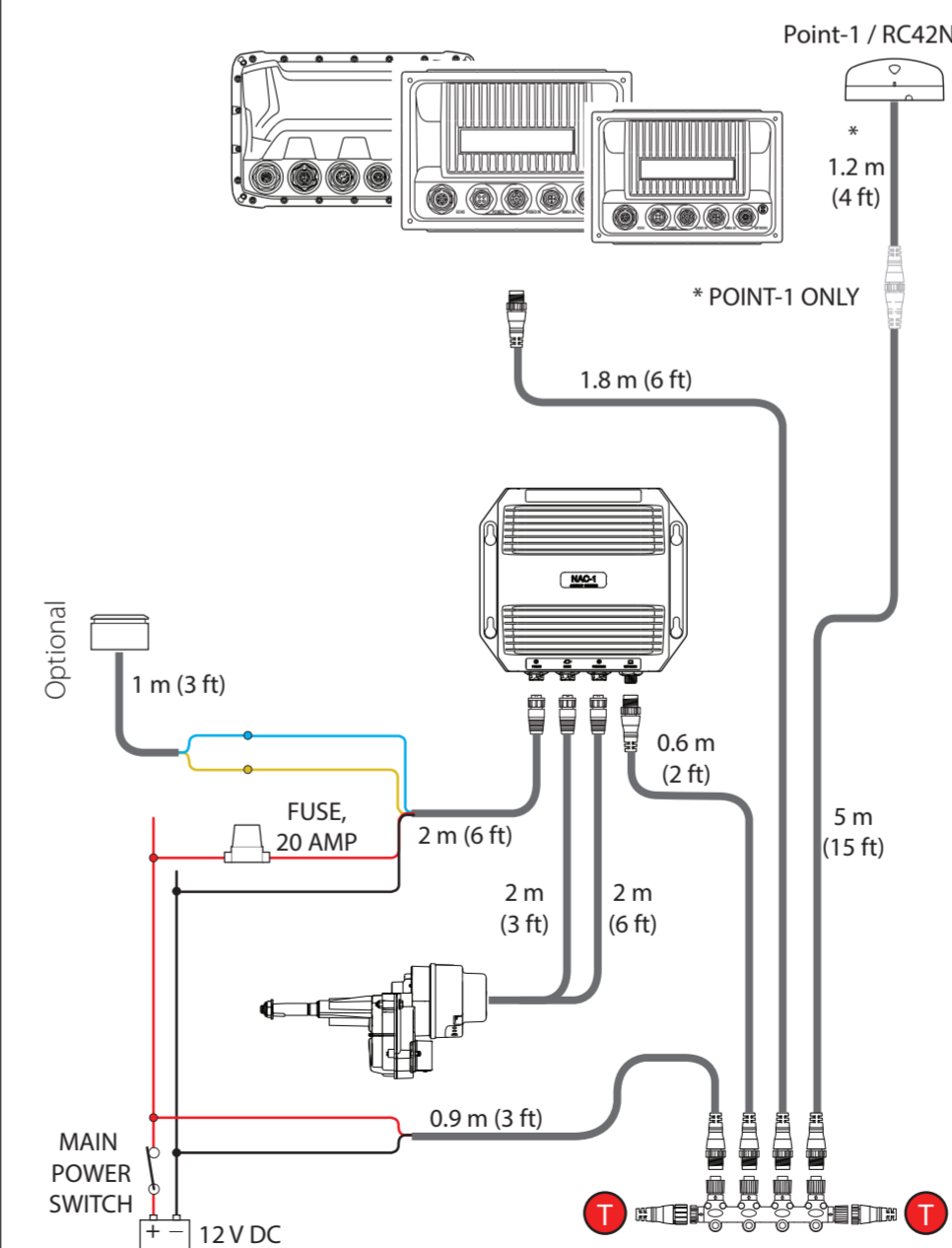

Configuration and reference

16

Refer to your Autopilot controller's documentation for setup instructions.



For more details about Helm-1, refer to the Straight Shaft Helm Drive manual, available for download on: www.simrad-yachting.com